

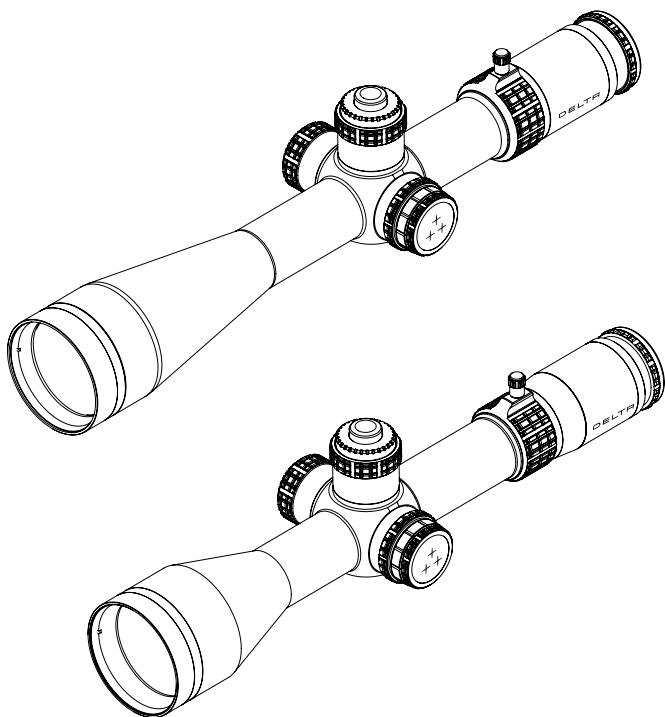

STRYKER HD

4.5-30x56 FFP

5-50x56 SFP



T H E A I M I S O P T I C A L P E R F E C T I O N

CAUTION!

Viewing the sun can cause serious eye injury, never look at the sun with this product or even the naked eye!

4 STRUCTURE OF THE RIFLESCOPE**5 CHARECTERISTIC****6 USE OF THE RIFLESCOPE**

- 6 Focusing (Diopter adjustment)
- 6 Mounting
- 8 Zeroing
- 10 Turrets scale zeroing
- 11 Using the zero-lock mechanism
- 12 Power adjustment
- 12 Illuminated reticle
- 13 Parallax adjustment
- 13 Sunshade

14 RETICLES CHARACTERISTICS

- 14 1. Stryker HD 4.5-30x56 FFP
- 15 2. Stryker HD 5-50x56 SFP

16 CARE AND MAINTENANCE

- 17 List of spare parts

Thank you for purchasing our riflescope. We hope that it will serve you well for many years. To maximize your enjoyment of the riflescope, please read this manual carefully.

STRUCTURE OF THE RIFLESCOPE

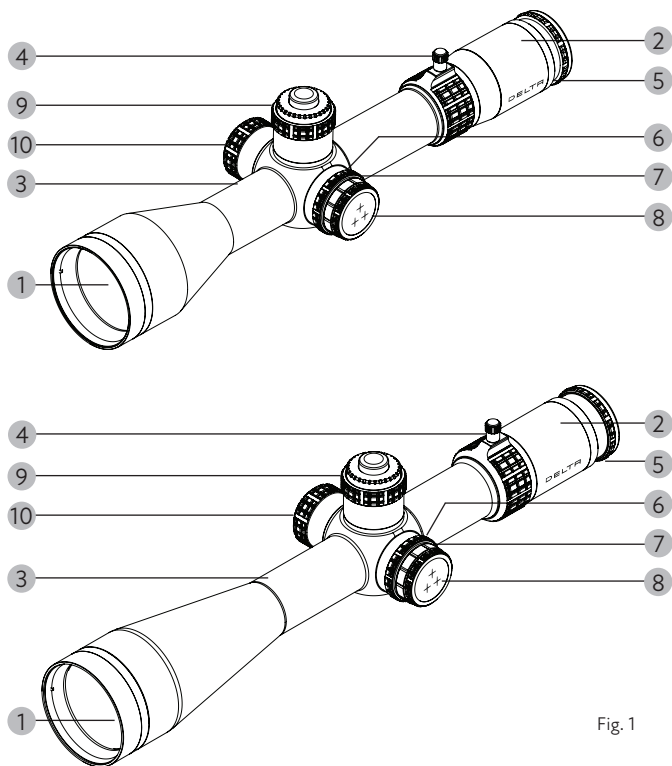

Fig. 1

- | | |
|-----------------------------------|-------------------------------------|
| 1. Objective lens | 6. Diopter ring |
| 2. Eyepiece | 7. Illumination adjustment rheostat |
| 3. Riflescope tube | 8. Battery compartment cover |
| 4. Power selector ring with lever | 9. Windage adjustment |
| 5. Side focus knob | 10. Elevation adjustment |

CHARACTERISTIC

Delta Optical Stryker HD is a riflescope designed for long-range sport shooting and hunting. Excellent image quality throughout the magnification range is guaranteed by the use of ED lenses.

Specially designed for use at all ranges, the following types of reticle are available:

Stryker HD 4,5-30x56 FFP: LRD-1T, LRD-1P, DLR-1 reticles

Scaled in milliradians (easy to convert into metric units) and corresponding to the riflescope clicks. 1 click is 0.1 mrad (10mm). The riflescope has a reticle located in the first focal plane.

Stryker HD 5-50x56 SFP: DLS-1, DLS-2 and DLS-3 reticles

DLS-1 and DLS-2 reticles are scaled in milliradians and DLS-3 reticle is scaled in arc minutes (MOA). The dimensions of the reticles correspond to the riflescope clicks - 1 click is 0.05 mrad (5mm) in DLS-1 and DLS-2 or 1/8 MOA (3.5mm) in the DLS-3 reticle. DLS-1, DLS-2 and DLS-3 reticles are placed in the second focal plane.

n

The reticle is illuminated with variable intensity .

The riflescope is equipped with parallax adjustment from 10m (Stryker HD 5-50x56 SFP scope) or 25m (Stryker HD 4.5-30x56 FFP scope) to infinity. The robust tube 34mm tube allows you to adjust the reticle 30 MIL (100 MOA).

The riflescope has open turrets equipped with a ZeroLock mechanism. The Stryker HD 4.5-30x56 FFP model is only 365 mm long and weighs only 1014g, while the Stryker HD 5-50x56 SFP model is only 363 mm long and weighs only 1100g.

USE OF THE RIFLESCOPE

CAUTION!

Viewing the sun can cause serious eye injury, never look at the sun with this product or even the naked eye!

Focusing (Diopter adjustment)

Hold the scope about 7-10 cm (3 - 4 inches) from your eye and look through the eyepiece at a featureless, flatly lit bright area such as a wall or open sky.

If the reticle is not sharply defined instantly you need to adjust focus. To do this, simply turn the adjustment ring at the end of the eyepiece (see Fig. 2).

If you intend to use prescription glasses in the future when shooting, adjusting the focus of the reticle should also be performed with them on.

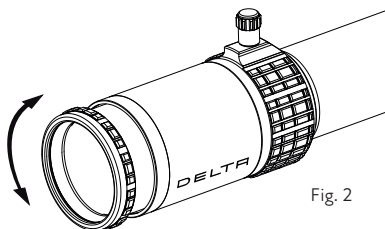

Fig. 2

Mounting

CAUTION!

Viewing the sun can cause serious eye injury, never look at the sun with this product or even the naked eye!

To achieve the best accuracy with your rifle, the scope must be mounted properly. Use high-quality mounts with bases designed to fit your particular rifle and take into account the diameter of the riflescope tube (34mm) and the objective (65,2mm). The scope should be mounted as low as possible without touching either the barrel or the receiver.

CAUTION!

If you decide to mount the scope yourself check the specification note at the end of this manual to ensure that this would not void the warranty.

With the rings pre-installed onto the firearm, separate the top and bottom halves of the rings. Set the scope in the cradles formed by the bottom ring halves. Replace the tops loosely. Do not tighten.

Position the scope as far forward as possible. Rotate the scope to position the elevation turret on top.

With the firearm in a steady rest position, slowly pull the scope to the rear until the full field of view becomes visible (to ensure maximum eye relief). Check the orientation of the reticle. The reticle must be vertical. This can be checked using a hanging plumb line.

With the scope properly positioned and the reticle aligned tighten the top halves of the rings evenly.

CAUTION!

Be sure that the firearm is not loaded. Practice safe firearm handling procedures at all times.

- The inner surface of the mounting rings should be free of dirt and degreased.
- Avoid fastening of the mounting rings on the riflescope's tube too loose. Riflescope's shift in the rings due to recoil may damage the tube.
- Avoid tightening the mounting rings on the riflescope's tube too tight as it may damage the riflescope or affect its optical properties. Check and use the tightening torque recommended by the mount manufacturer.
- We recommend having the riflescope mounted by an authorized, qualified gunsmith.
- Riflescope damage caused by incorrect mounting is not covered by the warranty.

CAUTION!

Avoid over-tightening the rings. This can damage the scope, affecting performance or rendering it inoperable. There should be a slight even gap on the left and right sides of both sets of rings, between the top and bottom halves. We recommend tightening the bolts with a torque wrench with a force not exceeding 1.7-1.8 Nm.

Zeroing**CAUTION!**

All discharging of firearms should be done at an approved range or equally safe area. Use of eye and ear protection is recommended.

Set parallax to the 100 meters position. Set magnification to the highest power. From a steady rest position, fire three rounds at a target 100 meters away. Observe point of impact on the target and correct aim.

Caution: first adjust mount to the scope!

Make major correction by adjusting mount to set up the point of impact about 15 cm from aim (adjust mount to riflescope). Then you can start to use windage and elevation screws.

The reticle adjustment turrets are set to the middle "0" position.

When zeroing, we recommend adjusting the turrets vertically or horizontally from the „0" setting by about one turn. Attempts at

much greater adjustments can cause spring blockage, reticle displacement and a parallax error. The turrets can have a locking mechanism to prevent them being knocked out of position accidentally. To unlock the turret, pull it up, and to lock again after completing your adjustment, press it down to lock it (Fig. 3).

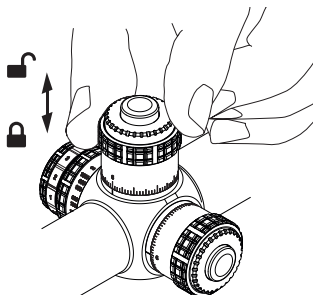

Fig. 3

For elevation adjustment, turn the elevation adjustment screw clockwise to lower the point of impact and counterclockwise to raise the point of impact. For windage adjustment, turn windage adjustment screws clockwise to move the point of impact to the left and counterclockwise to move the point of impact to the right. (Fig. 4)

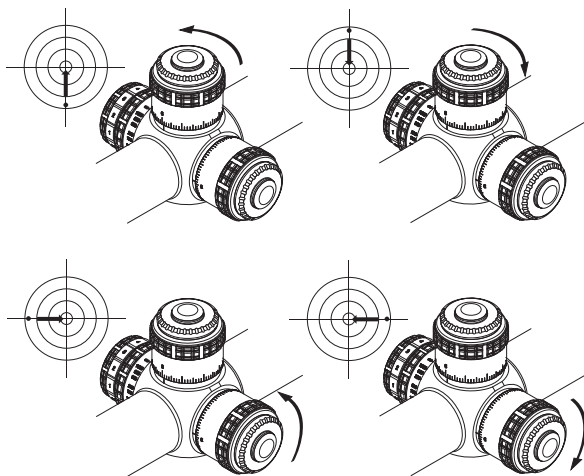

Fig. 4

If a large amount of adjustment is required to align the reticle, make approximately one-half of the required windage correction, then approximately one-half of the required elevation correction. Finish by applying the balance of windage and elevation correction.

Note: one click of adjustment changes bullet strike at a shooting distance of 100 meters by 0,1 mrad - 10mm on models with reticles LRD-1T, LRD-1P, DLR-1, or by 0,05 mrad - 5mm on models with reticles DLS-1, DLS-2, or by 1/8 MOA - 3.5mm on model with reticle DLS-3

Turrets scale zeroing

To realign the zero marks of windage and elevation turrets after completing the zeroing procedure, you can reset the turret's scale to zero.

In the case of the Stryker HD riflescope version with lockable turrets, to zero the scale, unscrew the ring on the top of the turret by hand (fig 5). Being careful not to change the position of the knob, remove the scale and set it so that the „0” point aligns with the start marker.

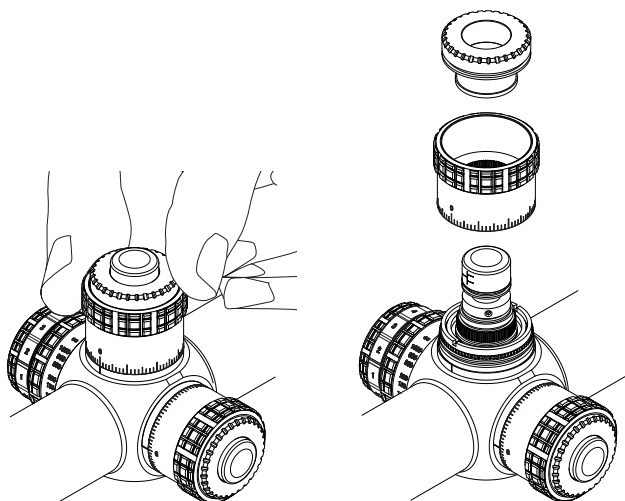

Fig. 5

Using the zero-lock mechanism

The riflescope is equipped with the „ZeroLock” mechanism that allows the user to set a lock for the vertical adjustment turret for specific settings - most often after zeroing the riflescope for a given shooting distance, e.g. 100m. This mechanism sets a hard stop on the elevation zero, so the user cannot accidentally be a whole turn of elevation out when dialling back to zero after taking a longer shot that required multiple turns of elevation on the turret.

Unscrew the ring on the top of the turret (fig 5). Then, using a 1.5mm Allen key, loosen the three lock screws located on the side of the „ZeroLock” locking ring (Fig. 6). After zeroing the riflescope set the locking ring and fix it by tightening the three counter screws. Be careful not to change the position of the turret and then set turret scale so that the „0” point aligns with the start marker. Finally, replace and tighten the turret scale.

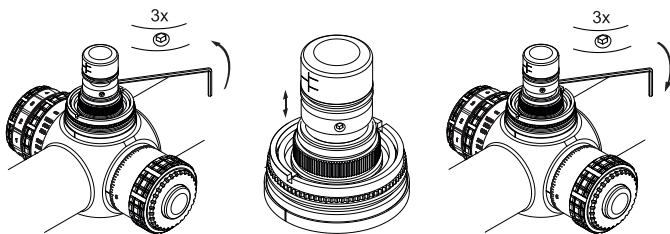

Fig. 6

Power adjustment

To change magnification, simply rotate the magnification ring to align the desired number on the power scale with the index dot. The adjustment ring is located between the eyepiece and tube of the riflescope. For your comfort of use, the ring has an additional lever. (Fig. 7)

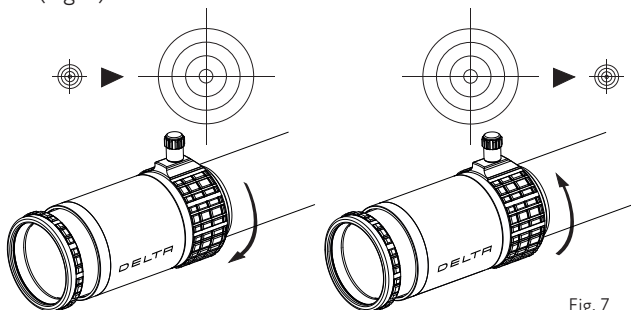

Fig. 7

Illuminated reticle

The riflescope has an 11-step adjustment of the illuminated point (DLR-1, DLS-1, DLS-2, DLS-3 reticles) or point with additional markers (LRD-1T and LRD-1P reticles). The brightness adjustment is located on the riflescope's body on the left next to the turrets, integrated with the parallax adjustment knob. See figure 8.

The illumination is powered by a 3V battery (CR2032 battery).

When replacing the battery, first unscrew the battery compartment lid. Remember to insert the battery with the correct polarity.

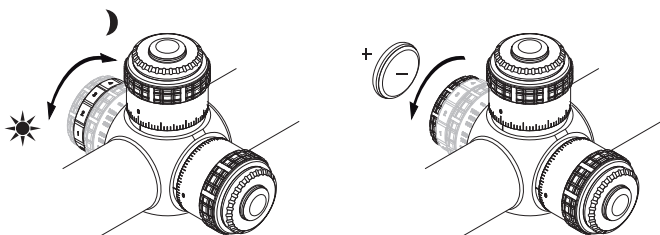

Fig. 8

Parallax adjustment

The riflescope is equipped with a side parallax adjustment knob to adjust focus to the target distance. Targets at any other distance will be affected by parallax shifts, which manifests itself as apparent movement of the reticle against a stationary target.

To adjust the parallax, turn the adjustment knob by selecting the appropriate distance on the scale or by looking through the riflescope turn the adjustment knob for a sharp image and a steady reticle when your eye is moved slightly. The parallax adjustment knob is located on the left side of the riflescope's body (fig. 9).

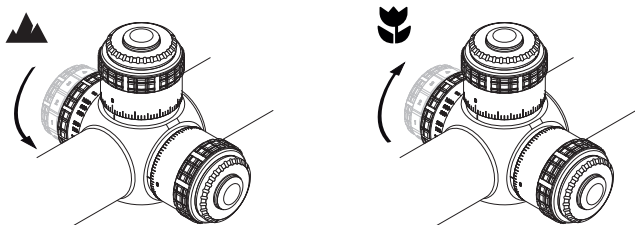

Fig. 9

The range of parallax adjustment beyond infinity allows you to fine-tune the focus when shooting at long distance.

Optionally, the riflescope can be equipped with a larger parallax adjustment wheel increasing the precision of settings and measuring the distance to the target, popular in various air rifle disciplines.

Sunshade

Stryker HD riflescopes come with a sunshade that increases the comfort of aiming especially in strong sunlight and also protects from rain splashes on the objective lens. To mount it, screw it into the threaded ring at the end of the lens housing. Front lens filter thread: M62x0,6mm.

RETICLES CHARACTERISTICS

Stryker HD 4.5-30x56 FFP

LRD-1P, LRD-1T and DLR-1 reticles were designed for ambitious shooters for PRS and tactical shooting at medium and long distances. The reticles ensure maximum comfort of shooting and high functionality throughout the zoom range (4.5-30x). Their unique features include quick and effective estimation of distance to the target, wind corrections and moving targets, as well as quick adjustments at low magnifications. The design of the reticles allows both the assessment of the distance to the object of known sizes, as well as correction for bullet trajectory and windage. The reticles were designed to work in the first focal plane (FFP) maintaining constant reticle scale over the entire zoom range. The reticles were scaled in milliradians and are easy to convert into metric units (1 milliradian = 10 cm per 100m).

LRD-1P

In the center of the reticle there is an illuminated point of diameter of 0.045 Mil with surrounding, also illuminated, markers forming a cross. Thin, very precise (0.03 Mil) crosshairs support aiming. The reticle offers the unique feature of quick measurements at a level of 0.1 Mil from the center of the reticle with an accuracy of 0.05 Mil and wind corrections with an accuracy of 0.1 Mil at a distance of 1 Mil from the center of the reticle. The horizontal bar at a distance of 7 miles from the center, as well as the lower vertical at a distance of 12 miles on the lower vertical bar go into thick bars increasing the visibility of the cross in difficult lighting conditions, useful especially in the lower zoom range.

LRD-1T

An extension of the LRD-1P reticle and has been additionally equipped in the lower section with a set of ballistic markers for quick adjustments for bullet drop, as well as windage or derivation adjustments.

DLR-1 reticle

There are two main sections of the reticle: the main cross and the side bar. The cross consists of thick horizontal bars passing at the center of the cross into thin bars and a thin vertical bar. The lower vertical arm extends to the end of the field of view, while the upper is shortened to increase transparency. Thin bars are 0.05 Mil (5 mm) thick and thick bars 0.4 Mil (4 cm). Bars are divided into markers into 0.2, 0.5 and 1 Mil sections (2, 5 and 10 cm respectively). The center of the cross is an illuminated point with a diameter of 0.07 Mil (7mm) allowing you to fire a precise shot even in conditions of limited visibility of the target. The additional side ruler allows accurate measurement of the target in the upper zoom range with the accuracy of up to 0.1 Mil (1 cm).

Stryker HD 5-50x56 SFP

DLS-1, DLS-2 and DLS-3 reticles, created especially for long shots, are the essence of precision and usability. These reticles are placed in the second focal plane and have been scaled to a magnification of 40x.

DLS-1

The central point only covers 3mm at 100m distance. The 0.005 Mil thick vertical and horizontal bars have markers spaced at convenient intervals every 0.2 and 1 Mil (2 and 10 cm/100 m respectively) to make adjustments for bullet drop or windage. The DLS-1 reticle, located in the second focal plane, is also perfect for smaller magnifications around 7-10x, when its center point is 17-12mm, also due to the convenient day and night illumination. The reticle is scaled in milliradians (Mil) and is easy to convert into metric units (1 Mil = 10 cm per 100m) and corresponds to riflescope clicks - 1 click is 0.05 Mil (5mm).

DLS-2

Pure precision. Two thin 0.005 Mil (0.5mm by 100m) lines intersect in the center at a 90 degree angle. Nothing distracts the shooter's sight for an optimal field of view. At the intersection there is a central illuminated aiming point.

DLS-3

Precise reticle, scaled in arc minutes (MOA). The central aiming point only covers 0.1 MOA (2.9 mm at 100 m). The 0.02 MOA (0.58 mm) bars have markers spaced at convenient intervals of 1 MOA (smaller) and every 5 MOA (larger) to make adjustments for bullet drop or windage. 1 click is 1/8 MOA (3.5 mm).

CARE AND MAINTENANCE

Your riflescope, though amazingly tough, is a precision instrument that deserves reasonable cautious care. Do not attempt to disassemble or clean the scope internally. If your scope ever does need repairs or adjustments, it should be returned to the distributor where the device was purchased.

The exposed optical surfaces will perform at their best if they are occasionally wiped clean with the lens cloth provided or with an optical quality lens paper like those for eyeglasses or camera lenses. When cleaning the lenses, first blow away any dirt and dust, or use a soft lens brush.

Warning! Unnecessary rubbing or use of a coarse cloth may cause permanent damage to the lens coatings.

Keep the protective lens covers in place when the scope is not in use.

Maintain the metal surfaces of your riflescope by removing any dirt or sand with a soft brush so as to avoid scratching the finish. Wipe the scope with a damp cloth and follow with a dry cloth. Finally, going over the tube with a silicone treated cloth will restore luster and protect the scope against corrosion. Be careful not to touch any of the lenses with the silicone cloth.

Store the scope in a moisture-free environment. Avoid storing the scope in hot places, such as the passenger compartments of vehicles on hot days. The temperatures could adversely affect the lubricants and sealants. A vehicle's trunk, a gun cabinet or a closet is preferable. Never leave the scope where direct sunlight can enter either the objective or the eyepiece lens. Damage may result from the concentration (burning glass effect) of the sun's rays.

List of spare parts

- | | |
|-------------------------------------|---------|
| • 56mm sunshade | DO-2905 |
| • Eyepiece and 56mm lens cover | DO-2913 |
| • Zoom lever | DO-2932 |
| • Turret cover 4,5-30x56 old design | DO-2940 |
| • Turret cover 5-50x56 old design | DO-2941 |
| • Turret cover new design | DO-2942 |

Warranty: 10 years

Delta Optical
Nowe Osiny, ul. Piękna 1
05-300 Mińsk Mazowiecki
www.deltaoptical.pl

